

SPRING WASHER TREP®



Secure tightening!

**TECHNICAL
DOCUMENTATION**

TREP® TAPERED

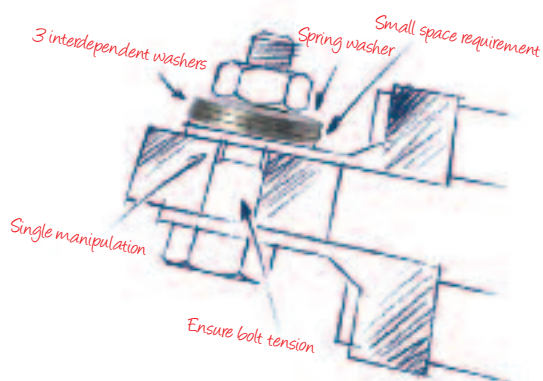

AN EXCLUSIVE, UNIVERSAL PRODUCT

GRIS DECOUPAGE is the EXCLUSIVE owner and manufacturer of the TREP® brand, an anti-loosening security system for all your mechanical bolted assemblies and all your electrical connection assemblies.

The TREP® spring washer consists of 3 or 4 interdependent smooth tapered spring washers assembled with a metal insert.

THE MAIN CHARACTERISTICS OF THESE COMPACT, HIGH-ENERGY-CONCENTRATION WASHERS ARE:

- Guaranteed resistance to loosening,
- Sustained tensioning of assembled elements,
- Even distribution of bearing pressure,
- High-stiffness, low-deformability elastic system,
- Ability to accommodate thermal expansion,
- Capacity to compensate and/or take up play (expansion, wear, etc.),
- Safe, easy assembly through crimping (only one part needs handling instead of 3 or 4),
- No marring of clamped components.

All these qualities make TREP® spring washers unique and UNIVERSAL in applications where safety is paramount.

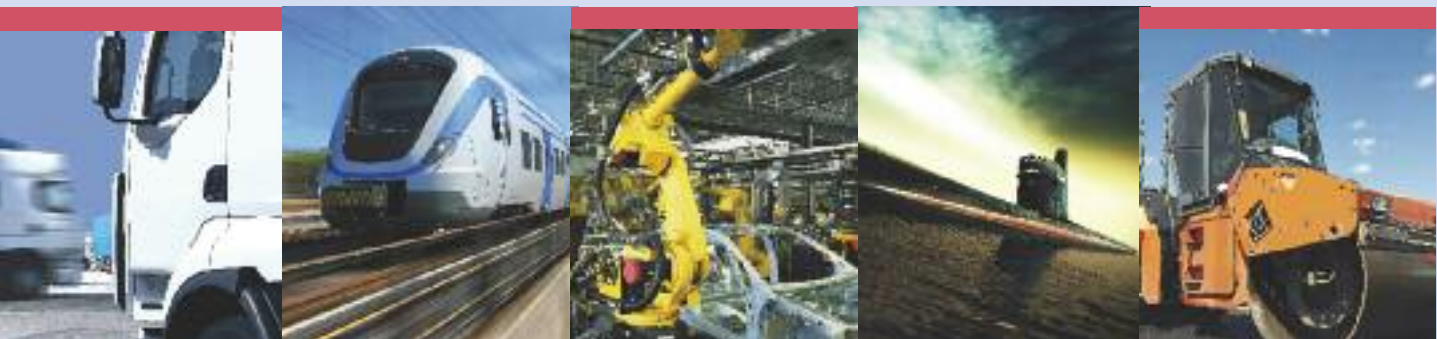

INDUSTRY BRANCHES

- rail,
- electrical equipment,
- public works equipment,
- heavy goods vehicles,
- shipbuilding,
- special machines subject to high vibrations.

SPRING WASHER

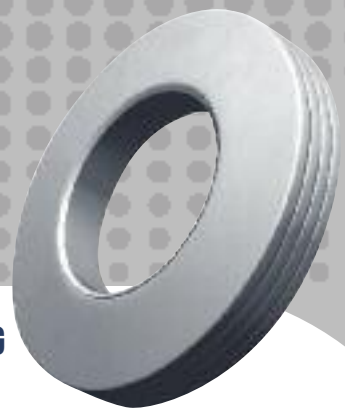

RESISTANCE TO LOOSENING UNDER HIGH TENSION!

In assemblies containing bolts of a high property class, resistance to loosening is achieved through the elasticity and taper of the TREP® spring washer. These features promote even distribution of the clamping force and maintenance of constant pressure in the assembled components.

At nominal tightening, one of the main characteristics of the TREP® spring washer is **to accurately maintain a high level of tension in the bolt** by drawing on a substantial reserve of elastic energy stored in a small volume.

Its operating principle is simple: clamped between two parts by a nut or bolt head, the interdependent spring washers flatten and act as a compressed spring between two components.

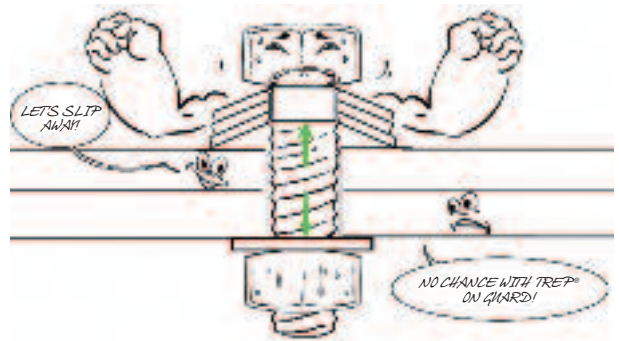

Even if tightening relaxes, the pressure is sustained by the spring effect delivered through the system's elasticity. The fastening is therefore totally reliable and wholly secure!

In addition, its taper promotes **even distribution of the clamping force** between the assembled items, as can be seen from the diagrams below. The colour gradient provides a good illustration of the uniformly distributed pressure at the component interface.

These diagrams clearly show that items clamped with an untapered washer are subject locally to higher and less evenly spread forces than parts assembled with a TREP® spring washer.

COMPRESSIVE STRESS DIAGRAMS

With an untapered washer
(flat, torque, serrated or toothed)

With a TREP® washer

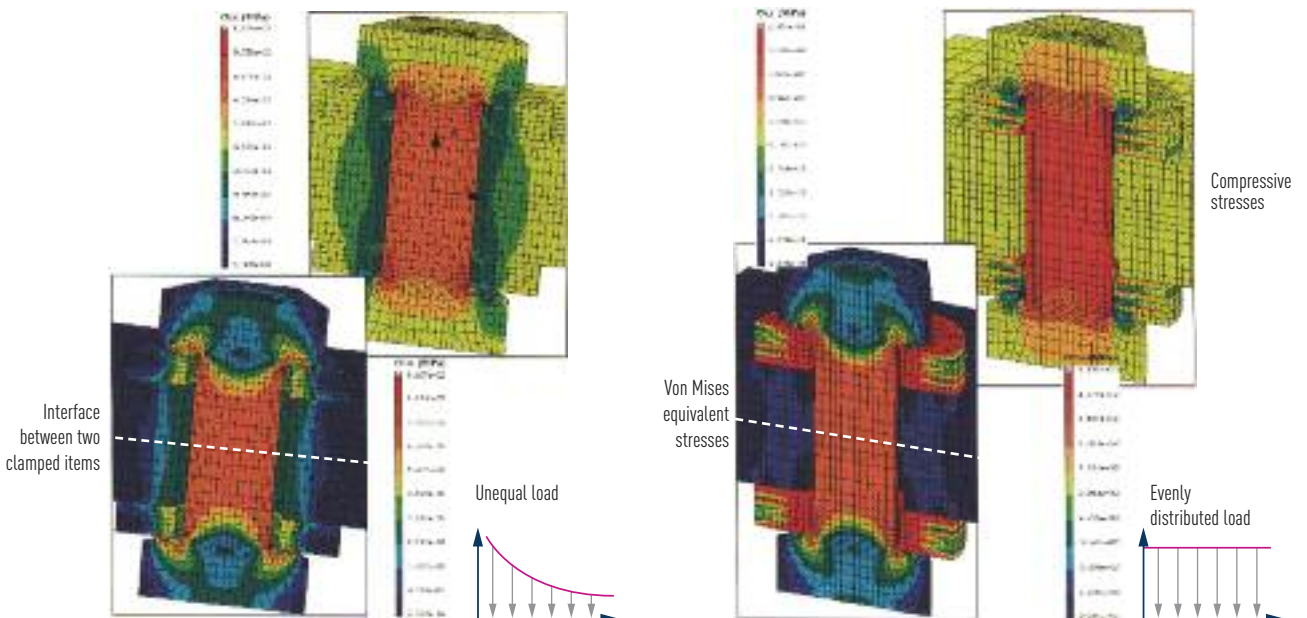

RESISTANCE TO Demonstration by

The elastic properties of TREP® spring washers ensure that the system will withstand loosening in high-stress applications where residual tension in the bolt is of vital importance.

After nominal tightening, a **mechanical assembly** may be subject to a variety of crushing or fatigue stresses. Unscrewing, although less frequent, is also possible, and marring may likewise occur.

In an **electrical assembly**, marking and marring of components are more frequent and problematic the lower the hardness of the mating surfaces. The use of a TREP® spring washer has also proved the most effective solution on the market to combat harmful stresses induced by thermal expansion.

→ In each of these cases, the superiority of our TREP® spring washers has been clearly demonstrated!

>>> 1st example of stress: Crushing in a mechanical assembly

When crushing occurs as a result of expansion of materials, wear or vibration, the TREP® spring washer takes up the play and through its elasticity helps maintain optimum tension in the assembly.

For example, for an assembly of diameter 10 class 8.8.

- With an untapered washer, such as a flat, serrated, torque or toothed washer, the assembly will very quickly become under-tightened as soon as crushing reaches 0.038 mm.
- With a tapered washer, under-tightening will occur at 0.18 mm of crushing.
- But with a TREP® spring washer, under-tightening only occurs at a much later stage when crushing exceeds 1 mm!

→ In an assembly containing a TREP® spring washer, tightening remains optimal.

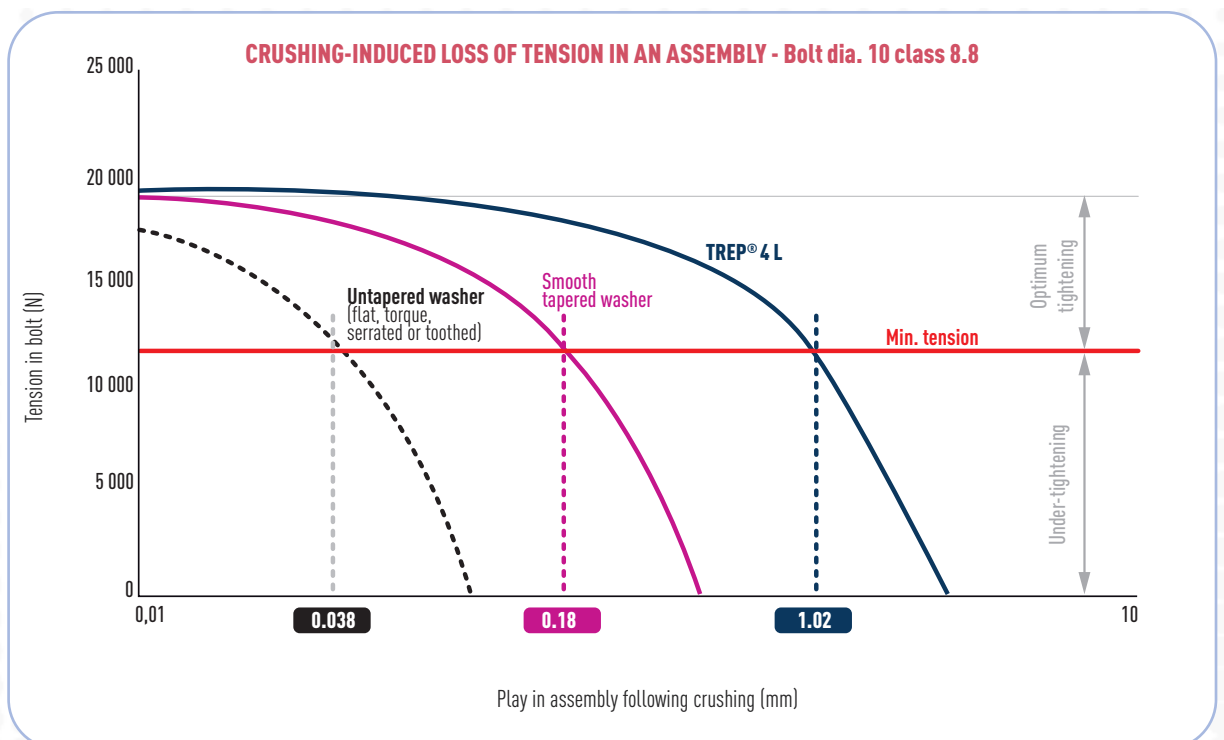

LOOSENING: THE PROOF!

calculation and experimentation

>>> 2nd example of stress: Fatigue stress

The fatigue test supplies important information as it provides a measure of the durability of the products.

Fatigue testing has established that an assembly containing a TREP® spring washer has a better fatigue life than any other system.

At the CETIM approved national laboratory we conducted a series of tests on a Vibrophore machine specially designed to determine the fatigue life of an assembly. The bolts in the assembly were instrumented with strain gauges to monitor the tension.

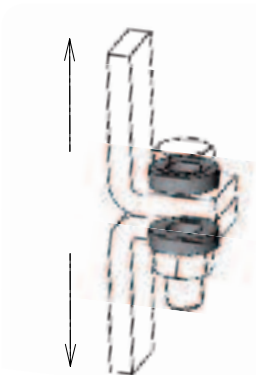

FATIGUE RESISTANCE OF 4 ASSEMBLIES OF DIAMETER 12 SUBJECT TO OFF-CENTRE DYNAMIC FORCES.

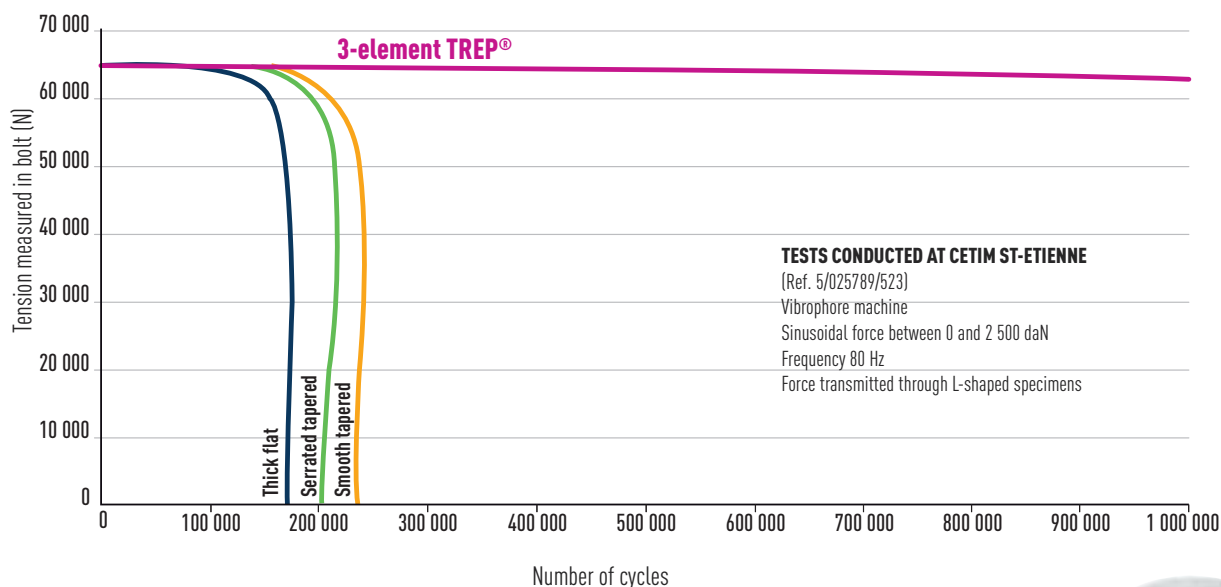

→ These tests revealed that assemblies containing TREP® spring washers retain their properties even after 1 000 000 cycles. In contrast, when flat, serrated tapered or smooth tapered washers are used, these prove to have a resistance of less than 300 000 cycles!



RESISTANCE TO Demonstration by

>>> 3rd example of stress: Unscrewing test

The TREP® spring washer also offers high resistance to unscrewing without damaging the surfaces it is fastened to.

Unscrewing is in fact a rare phenomenon among the causes of loosening. Unscrewing can be simulated in a destructive Junker vibration test with highly informative results.

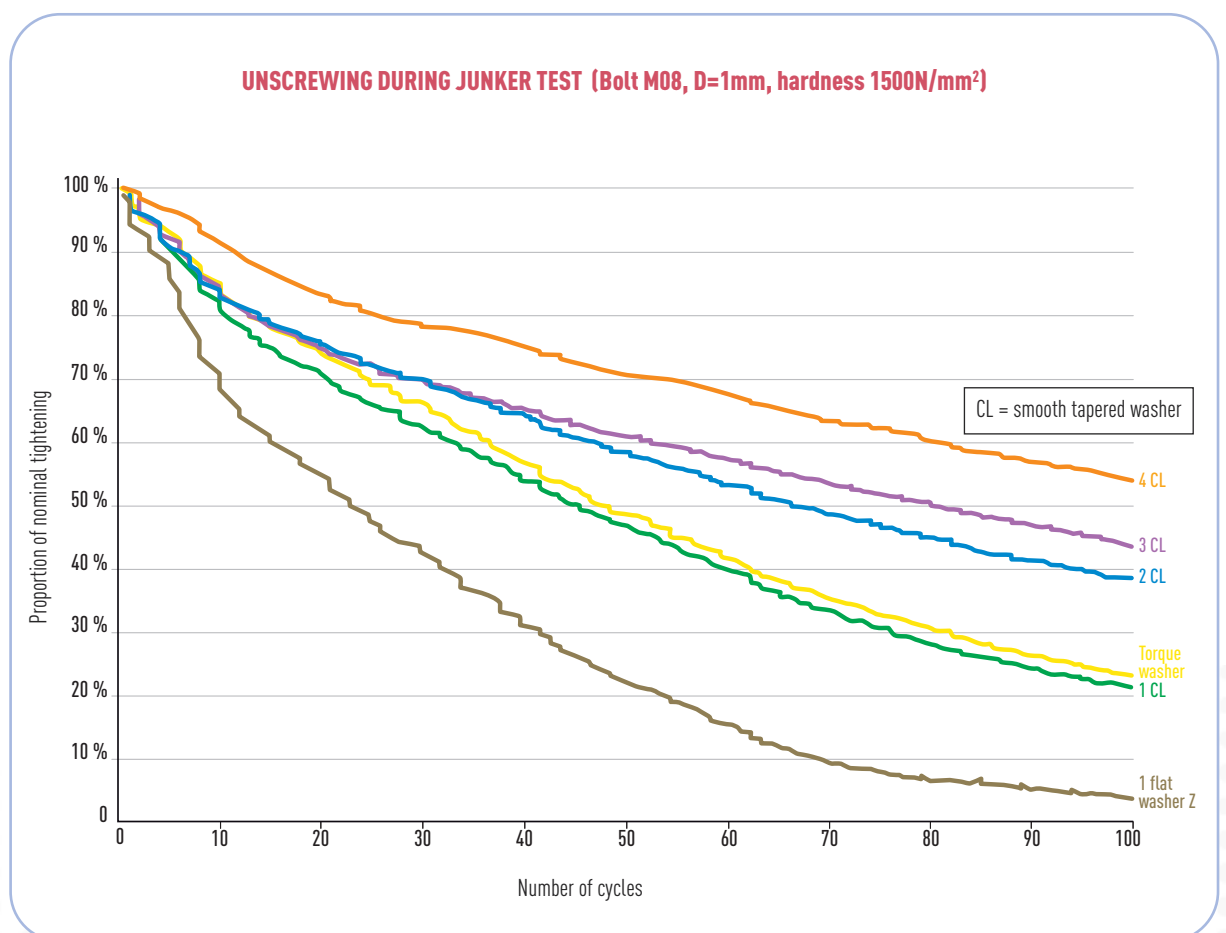

→ Tests conducted on M08 bolts show that the amount of unscrewing reduces as the number of tapered washers in the assembly increases.

TREP® fastenings with 3 or 4 tapered washers are therefore extremely reliable in an assembly where unscrewing must be limited. They are also practical to use as the washers are interdependent.



Machine on which the Junker test is performed

LOOSENING: THE PROOF!

calculation and experimentation

>>> 4th example of stress: Thermal expansion in an electrical assembly

What is required in an electrical connection is an element possessing both **STIFFNESS** and **RANGE OF MOVEMENT**: two conditions fulfilled by TREP® spring washers.

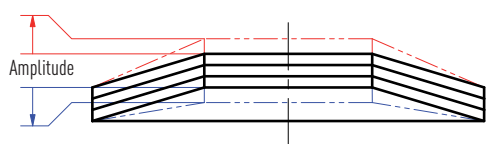

- The TREP® spring washer is sufficiently stiff not to flatten out completely under preload or nominal tightening.
- The TREP® spring washer has sufficient range of movement to accommodate any thermal expansion that may occur during the life of the assembly.

To evaluate the variations in tension in a bolt as a result of thermal expansion, the following formula may be applied:

In an assembly containing a bolt B holding parts P at nominal tightening with a prestress characteristic Q in the bolt, if the assembly is subject to a variation in temperature ΔT , this amounts to adding to the prestress Q a component Q_t written as follows:

$$Q_t \approx \left[\frac{l_p}{\frac{1}{K_B} + \frac{1}{K_P}} \right] \times (\alpha_P - \alpha_B) \Delta T$$

where
K = stiffness
 α = linear thermal expansion coefficient
l = tightened height

EXAMPLE OF NUMERICAL APPLICATION TO DIAMETER 10 FOR ALUMINIUM CONNECTIONS SUBJECT TO A 40° C TEMPERATURE VARIATION.

- For TREP® spring washers,
the additional stress obtained is limited to 300 N:

$$Q_t \approx \left[\frac{20}{\frac{28.8}{210\,000 \times 58} + \frac{20}{75\,000 \times 150} + \frac{4}{210\,000 \times 150} + \frac{1}{40\,000}} \right] \times (23.8 - 12) \times 10^{-6} \times 40 \approx 300N$$

- For serrated tapered washers,
the additional stress is much higher at 2400 N:

$$Q_t \approx \left[\frac{20}{\frac{25.6}{210\,000 \times 58} + \frac{20}{75\,000 \times 150} + \frac{4}{210\,000 \times 150} + \frac{1.6}{210\,000 \times 150}} \right] \times (23.8 - 12) \times 10^{-6} \times 40 \approx 2400N$$

→ Therefore, the effects of expansion on the assembly are reduced to one-eighth when TREP® spring washers are used. These results also explain why the use of TREP® safety spring washers is recommended in French standard NFF 61-021 to compensate for thermal expansion.



>>> 5th example of stress Marring phenomenon

TREP® spring washers provide a large reservoir of anti-loosening energy whatever the hardness of the material, since they do not need to be anchored in the mating surface to operate efficiently.

In contrast to serrated or torque washers, which always mar the bearing surface and render the assembly non-mechanical, the TREP® spring washer is geometrically designed not to cause this phenomenon.

Nevertheless, as a precaution when systems are assembled on soft materials, it is advisable to interpose an appropriately sized flat washer.

THE TREP^{plus} SPRING WASHER, THE SOLUTION FOR SOFT MATERIAL

That is why, alongside our TREP® spring washers, we have developed the TREP^{plus}® spring washer for use specifically on soft materials such as copper, aluminium or brass.

This is a system consisting of 3 or 4 smooth tapered spring washers together with a flat washer of larger outside diameter, all rendered interdependent by a metal insert.



MAIN CHARACTERISTICS:

- Distribution of clamping force over a large surface area
- Safe, easy assembly through crimping (only one part needs handling instead of 3 or 4)
- No slipping.

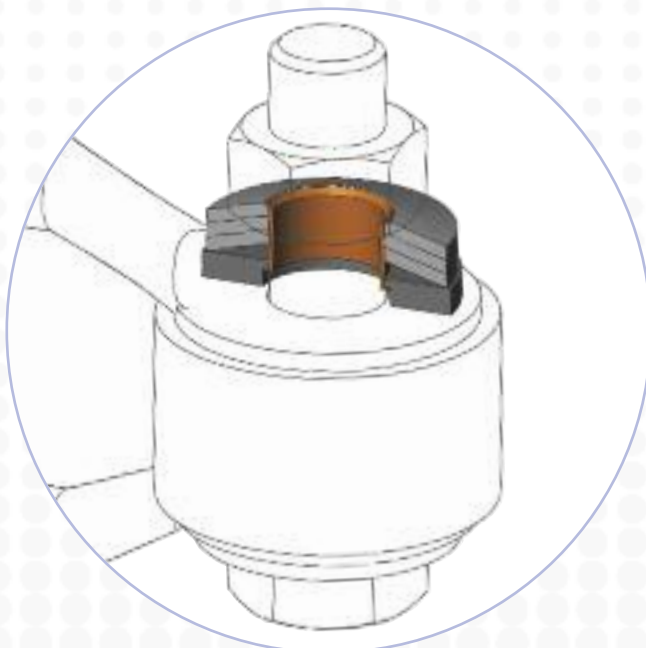

Materials & treatments

TREP® and TREP INOX® spring washers are manufactured in compliance with RoHS and ELV directives.

- TREP® SPRING WASHERS are made from carbon steel C > 0.75%. Their spring characteristics are obtained after core hardening.
- TREP INOX® SPRING WASHERS are made from tempering stainless steel X8 CrNiMoAl. Their spring characteristics are obtained after precipitation hardening heat treatment.

Whichever version is chosen, our TREP® and TREP INOX® spring washers perform the same duties and achieve the same results in a compact format.

Hardness

Family	Range	Unprotected
TREP®	3L4 - 3L20 4L6 - 4L60	40 - 48 HRC
TREP INOX®	3L4 - 3L16 4L6 - 4L20	40 - 48 HRC



High-temperature resistance

The high-temperature resistance of TREP® and TREP INOX® spring washers is identical to that exhibited by bolts and nuts of similar materials. Mechanical characteristics are guaranteed up to 200° C. Contact us for applications up to 700° C.

Corrosion resistance / salt spray resistance

TREP® and TREP INOX® spring washers are available in different finishes for different environments and stresses. Depending on requirements, their resistance can vary from 96 to 1 000 hours in salt spray as per standard ISO 9227.

No lubrication needed!

If you use TREP® spring washers in your assemblies, tightening is guaranteed regardless of the friction coefficients. No lubrication is required and no chemical additives are necessary.

Quality tests

All mechanical characteristics of TREP® and TREP INOX® spring washers comply with our in-house quality requirements.

All batches of electrolytically coated items are tested for fragility in accordance with standard NFE 25 510.



TECHNICAL CHARACTERISTICS

Fields of application of TREP® spring washers

	MECHANICAL component assembly	ELECTRICAL connection assembly
REQUIREMENTS	<ul style="list-style-type: none"> • Clamp components in the assembly to one another • Avoid all slipping or separation between components 	<ul style="list-style-type: none"> • Control clamping force to ensure there is sufficient contact surface area (avoid overheating and achieve good electrical contact) • Take up play due to thermal expansion and creep of materials
TIGHTENING TORQUE STANDARDS	<ul style="list-style-type: none"> • 85% of Re specified for bolt property class (NFE 25-030) 	<ul style="list-style-type: none"> • NFF 61-011 (copper connection) • NFF 61-021 (aluminium connection)
MAIN STRESSES	<ul style="list-style-type: none"> • External force (axial or transverse to bolt) • Vibrations • Fatigue 	<ul style="list-style-type: none"> • Thermal expansion of dissimilar materials (steel, copper, aluminium) • Creep of materials (e.g. copper after current flow – crushing phenomena) • ONLY SMALL AMOUNT of external force
BOLT CLASS	8.8 / 10.9 / 12.9	5.8 / 6.8 / 8.8
TREP® RESPONSES	TREP® spring washer when flat: <ul style="list-style-type: none"> • High load in a small volume • Keeps components in tension • Distributes the load 	TREP® spring washer at approximately 50% of its flattening load (+ flat washer): <ul style="list-style-type: none"> • "Absorbs" play as a flexible component, unlike fully flattened products (stiff component)

Choose a TREP® spring washer with 3 or 4 elements

For MECHANICAL assemblies where the washers are tightened FLAT

YES to TREP®3L spring washers for high bolt property classes ≥ 8.8

The use of TREP® spring washers with three elements, known as "3Ls", is appropriate for high bolt property classes from 8.8 to 12.9. 3Ls are not compatible below class 8.8 as the tensions in the bolts are too low to fully flatten the washers.

YES to TREP®4L spring washers for less high bolt property classes ≤ 8.8

TREP® spring washers with four elements, known as "4Ls", are more flexible. The flattening force is less than for 3Ls and the range of movement is greater. TREP® 4L spring washers are therefore recommended for less high bolt property classes from 5.6 to 8.8.

For tightening ELECTRICAL connections where the washers are not tightened FLAT

YES to TREP® 3L spring washers

The use of TREP®3L spring washers is recommended by standards NFF 61-011 and NFF 61-021 used in electrical assemblies. As the bolt property classes are less high because of the use of soft materials, the TREP®3L spring washers are deliberately not fully flattened in order to accommodate any thermal expansion due to electrical overheating.

NO to TREP®4L spring washers

Whatever the bolt property classes, TREP®4L spring washers are always tightened fully flat. That is why they are not recommended for electrical connections.

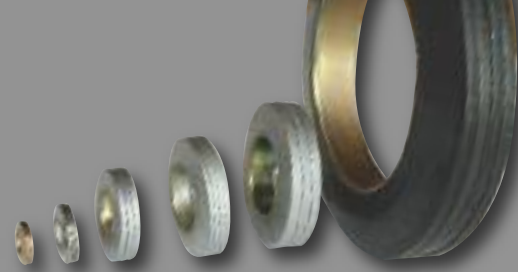

Dimensions of TREP® spring washers

AVAILABLE FROM STOCK

TREP®3L SPRING WASHER

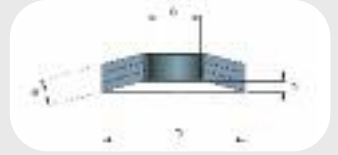

Bolt dia.	D	d	Thickness e	h	Net weight per 1000 items	Test load*	h after test	Stiffness 1* electrical connections	Stiffness 2* class 8.8	Stiffness 3* class 10.9
	mm	mm	mm	mm	kg	daN	mm	kN/mm	kN/mm	kN/mm
4	10	4.5	1.5	0.50	0.22	150	0.30	na	20	30
5	12	5.5	2.4	0.30	0.48	360	0.20	15	35	60
6	14	6.5	2.4	0.60	0.67	400	0.38	15	30	50
8	18	8.5	3.6	0.56	1.69	1 200	0.34	25	40	50
10	22	10.5	4.5	0.60	3.18	2 100	0.41	60	60	70
12	27	12.5	5.4	0.80	5.96	2 300	0.53	50	50	120
14	30	15.0	6.0	1.05	7.85	2 800	0.64	60	60	160
16	33	17.0	6.6	1.25	11.17	4 000	0.80	75	60	270
18	36	19.0	7.5	1.09	13.43	4 800	0.77	100	120	280
20	40	21.0	9.0	1.15	20.64	6 000	0.71	110	80	320

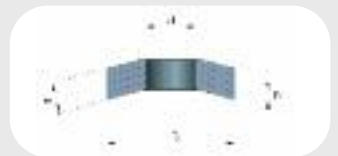

TREP® 4L SPRING WASHER

Bolt dia.	D	d	Thickness e	h	Net weight per 1000 items	Test load*	h after test
	mm	mm	mm	mm	kg	daN	mm
6	17	6.5	2.4	0.80	0.9	320	0.60
8	20	8.5	2.8	0.95	1.3	400	0.70
10	23	10.5	3.2	1.05	2.0	600	0.80
12	26	12.5	4.0	1.30	3.0	1150	1.00
14	29	15.0	4.8	1.30	4.3	1300	0.90
16	33	17.0	4.8	1.40	5.7	1250	1.10
18	37	19.0	6.0	1.52	9.0	2100	1.20
20	41	21.0	6.0	1.85	10.8	2100	1.40
22	45	23.0	7.2	1.67	15.3	2700	1.40
24	50	25.0	7.2	1.84	19.7	2900	1.60
27	56	28.5	8.0	1.80	27.6	3600	1.60
30	60	32.0	8.8	2.30	33.6	4200	1.80
33	64	35.0	10.0	2.57	41.9	6300	2.00
36	68	38.0	10.0	2.50	46.0	6200	2.00
39	72	41.0	10.0	2.45	48.6	5500	2.20
42	76	44.0	10.0	3.20	55.7	5700	2.40
45	80	47.0	10.0	2.75	60.9	6500	2.50
48	85	50.0	10.0	2.85	68.9	5700	2.60
52	90	54.0	12.0	3.55	90.8	7500	2.80
56	95	58.0	12.0	3.22	99.3	7200	3.00
60	100	62.0	12.0	3.25	108.1	7000	3.00

Load curves of TREP® 3L and tightening fields

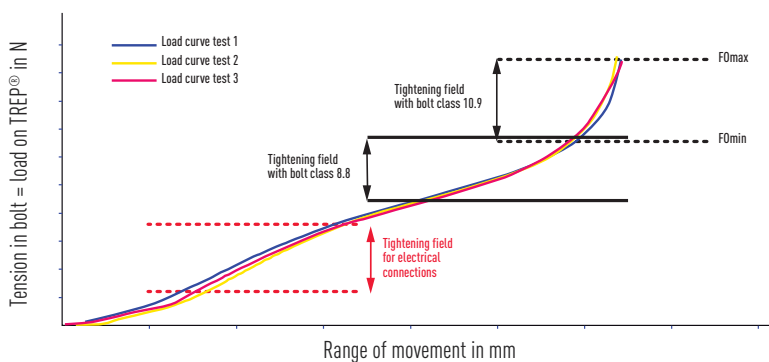

* Test load: guarantees that a TREP® spring washer cannot be fully flattened under a load less than the test load.

Stiffness: secant stiffness determined from the experimental load curves of TREP® spring washers between F_{0min} and F_{0max} according to the tightening recommended by the standard:

- stiffness 1 = stiffness on electrical connections (standards NFF 61-011 and NFF 61-021)
- stiffness 2 = stiffness on bolts of class 8.8, tightening precision C, μ average=0.15 (standard NF25-030)
- stiffness 3 = stiffness on bolts of class 10.9, tightening precision C, μ average=0.15 (standard NF25-030)

TREP® TREP INOX® TREP PLUS®

are trademarks registered by
GRIS DÉCOUPAGE

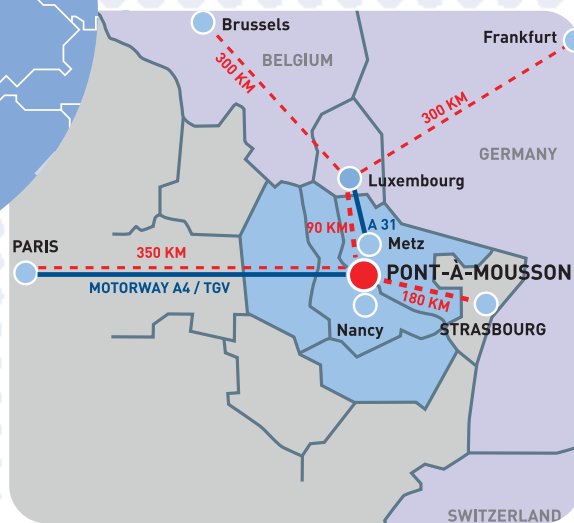

GRIS DÉCOUPAGE

Zone Industrielle de Lesménils -
BP 185 F-54706 PONT-A-MOUSSON CEDEX
France

Tel. : +33 (0)3 83 80 80 06

Fax : +33 (0)3 83 80 80 20

accueil@gris-decoupage.com

